

# Electronic Stability Control (ESC)

## Benefits

- Cost-optimised by modular system design and standardisation
- Compact design, low weight and small package size with industry standard interface
- High integration capability with other vehicle safety systems
- New microprocessor generation with significantly extended RAM / ROM size and speed
- NVH reduction and increased motor lifetime by high frequency motor speed control (20 kHz)
- Capable of integrating EPB
- Minimal NVH
- Applications from A-segment to heavy-duty truck
- Possible integration of customer-specific software modules and hardware interfaces (including low-cost driver assist functions)



ZF TRW's ESC systems combine anti-lock brakes (ABS) and traction control with a lateral stability control function. ESC systems are specifically designed to help control and maintain the lateral stability of the vehicle. If a potential loss of vehicle control is sensed, ESC automatically applies brake pressure to the appropriate wheel(s) and, if necessary, cuts engine throttle to help bring the vehicle back in line with the driver's intended path. The ESC systems also provide industry-leading comfort and pedal feel / pulsation with long-life durability. Further noise reduction is also obtained with the high frequency motor speed control option.

## Features

- Improved pressure control performance and comfort for all ABS / ESC and adaptive cruise control (ACC) controls
- Master cylinder hydraulic ports on motor face
- Integrated, redundant pressure sensor
- Integration of ESC sensors (yaw and acceleration) and electric park brake (EPB) electronics into the electronic control unit

## Technical Specification Outline

Motor	330 W
Weight	1.82 kg

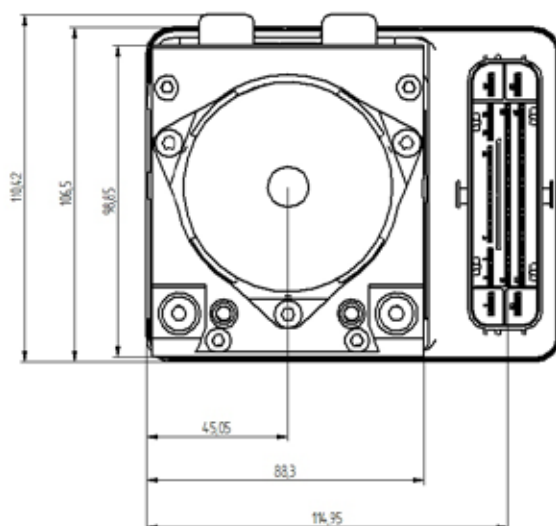
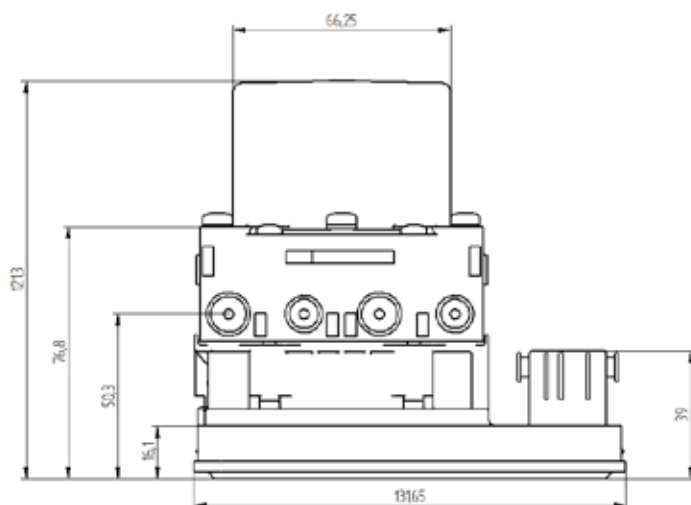

conekt